

PARTS LIST			
ITEM	QTY	PART NUMBER	DESCRIPTION
1	1	2155-3063-1	ZINC DIECAST - FLOOR TRAP BODY- CHROME PLATED
2	1	2155-3063-2	ZINC DIECAST - RING PULL HANDLE - CHROME PLATED
3	1	2155-3063-3	M/STEEL - SPRING - NATURAL

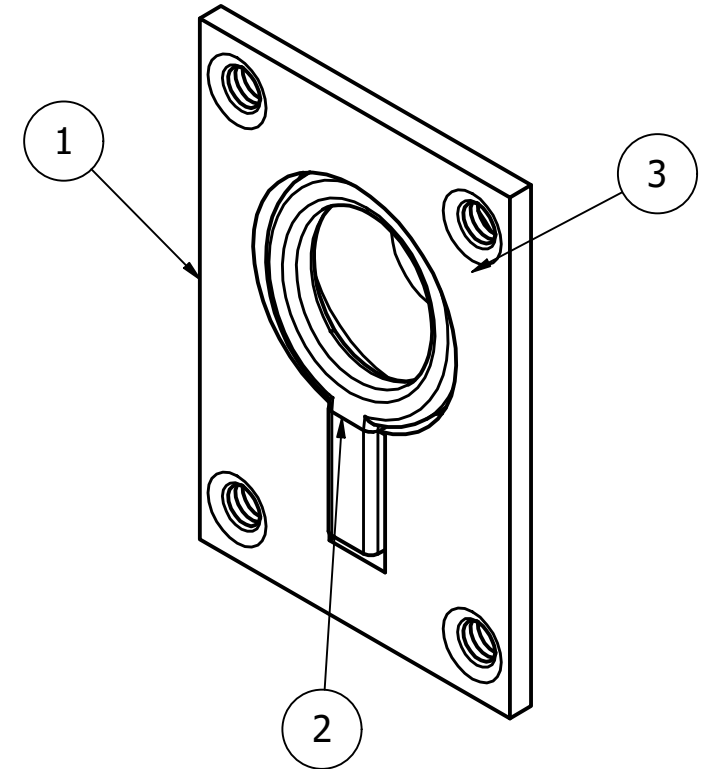
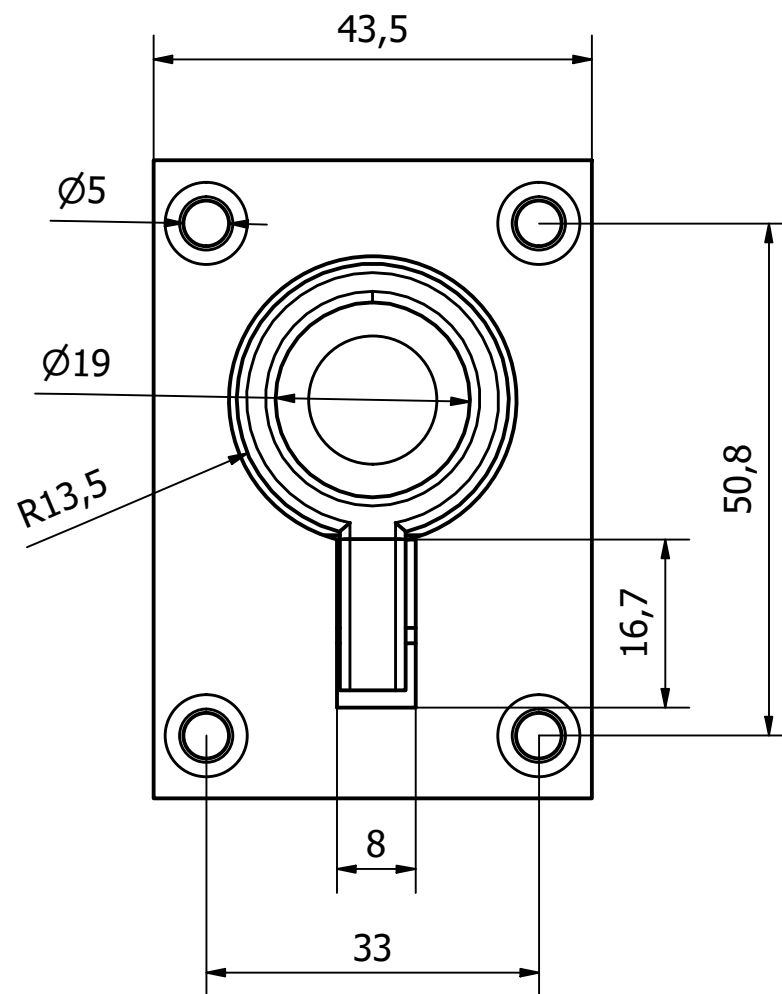
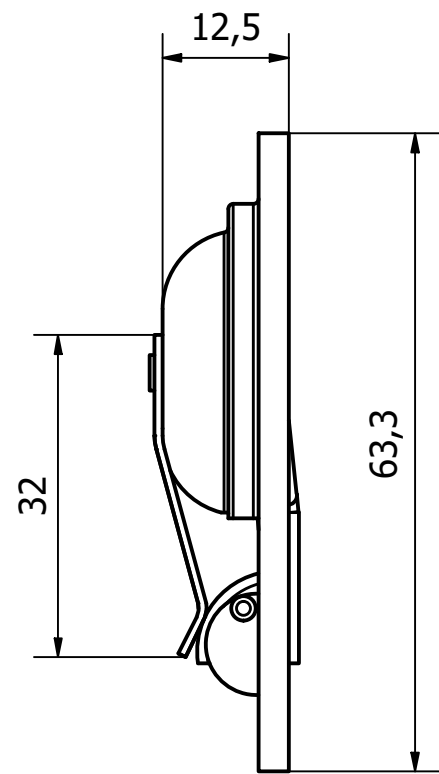
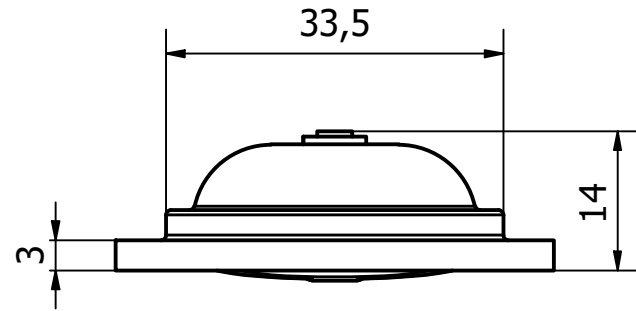

1	VALIDATION COMPLETE	07/01/2022	C.H
REV	DESCRIPTION	DATE	APPROVED

GENERAL TOLERANCES ON LENGTHS	
0.5 - 6 ± 0.1mm	
6 - 30 ± 0.2mm	
30 - 120 ± 0.3mm	
120 - 400 ± 0.5mm	
400 - 1000 ± 0.8mm	
1000 - 2000 ± 1.2mm	
2000 - 4000 ± 2.0mm	

ALBERT JAGGER LTD
 GREEN LANE
 WALSALL PHONE: 01922 471000
 WEST MIDLANDS FAX: 01922 648021
 WS2 8HG

THIS DRAWING & THE DESIGN SHOWN ARE THE PROPERTY OF ALBERT JAGGER LTD AND MUST NOT BE USED OR COPIED BY A THIRD PARTY WITHOUT PERMISSION

DRAWN BY S.R
 CHECKED BY C.H
 SCALE 2: 1.5
 MATERIAL SEE TABLE
 MASS 0.062 kg
 FINISH SEE TABLE
 Date 13/12/2021
 ALL DIMS IN MM UNLESS STATED DO NOT SCALE

albert Jagger

FLOOR TRAP RECESSED FINGER PULL

2155-3063

Edition 1 Sheet 1 / 1