

IF IN DOUBT ASK

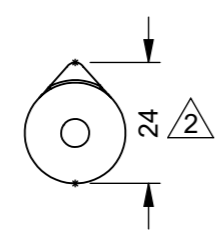

ITEM NO.	PART NUMBER	DESCRIPTION	QTY.
1	2217-010-1.ipt	CARBON STEEL HINGE BASE	1
2	2217-010-2.ipt	BRASS BEARING WASHER	1
3	2217-010-3.ipt	CARBON STEEL MOUNTING BLOCK	1

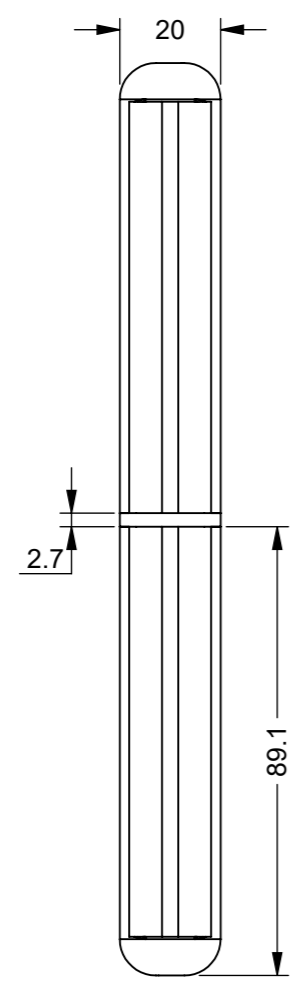
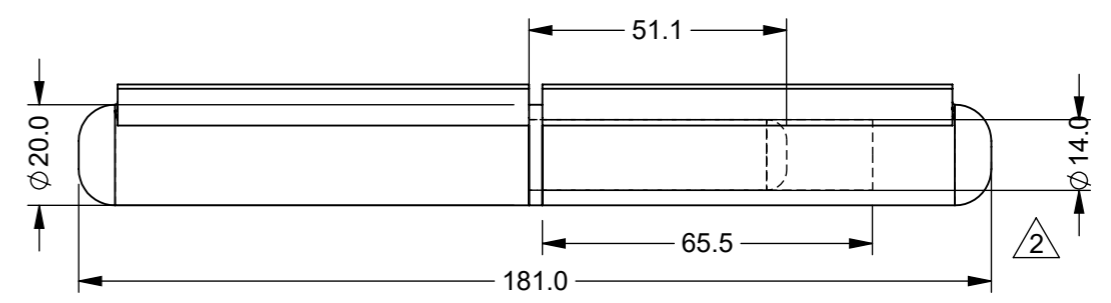
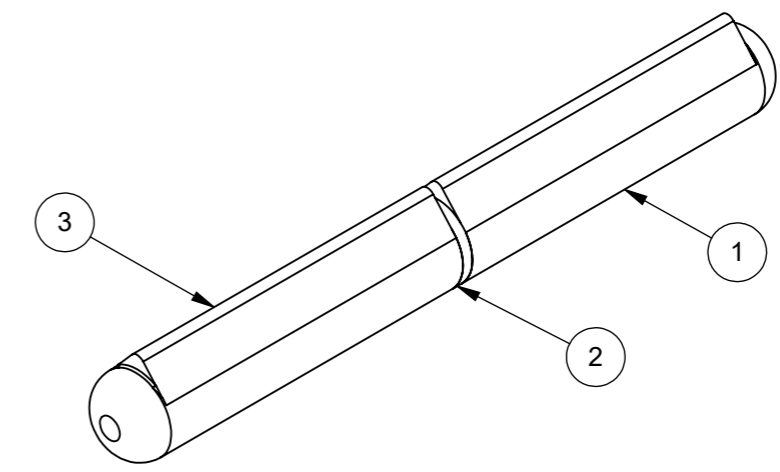

ZONE	REV.	DESCRIPTION	DATE	APPROVED
D2, D6	2	RE-DRAWN IN SOLIDWORKS AND DIMENSIONS UPDATED	20/11/2023	L.B.H

REVISIONS

UNLESS OTHERWISE STATED, ALL DIMENSIONS IN mm	
TOLERANCES	SURFACE FINISH 1.6um Ra
0.5 - 6 = ±0.1mm	FILLET RADII 0.5 TO 1.0
6 - 30 = ±0.2 mm	SQUARENESS 0.05 IN 25
30 - 120 = ±0.3 mm	PARALLELISM 0.05 IN 25
120 - 400 = ±0.5 mm	RUNOUT 0.1
400 - 1000 = ±0.8 mm	ANGLES ±0.5°
1000 - 2000 = ±1.2 mm	
2000 - 4000 = ±2.0 mm	

MATERIAL: SEE TABLE	DRAWN BY: L.B.H	DESCRIPTION: WELD ON LIFT OFF HINGE - 181 O/A		A3	
MASS: 0.47	CHECKED BY: U.F	NUMBER: 2217/010	REVISION: 2		SHEET: 1 of 1
FINISH: NATURAL	APPROVED BY: A.P	ORIGINATION DATE: 21/11/2023	SCALE : PROPORTIONAL - DO NOT SCALE REF SCALE 1:2 WHEN PRINTED ON A3		

PROPRIETARY RIGHTS ARE INCLUDED IN THE INFORMATION DISCLOSED HEREIN. NEITHER THIS DOCUMENT NOR ANY INFORMATION DISCLOSED SHALL BE REPRODUCED, USED, TRANSFERRED TO OTHER DOCUMENTS, OR DISCLOSED TO OTHERS FOR ANY PURPOSE INCLUDING MANUFACTURING UNLESS SPECIFICALLY AUTHORISED IN WRITING
REMOVE ALL SHARP EDGES AND BURRS
PART FINISHING AND MARKING TO CESF001

