

IF IN DOUBT ASK

IF IN DOUBT ASK

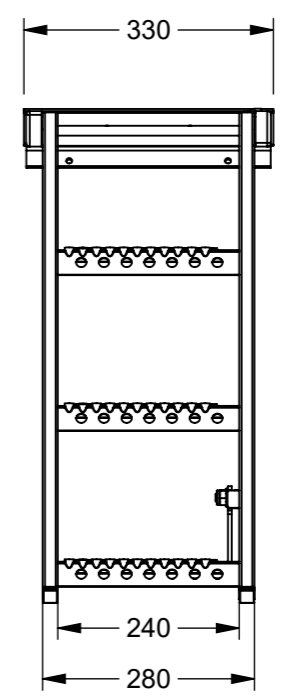
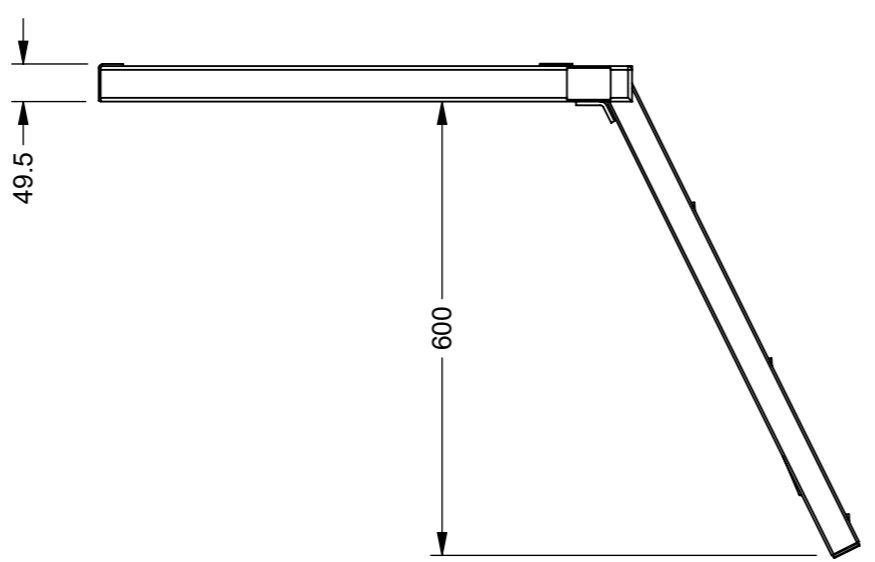
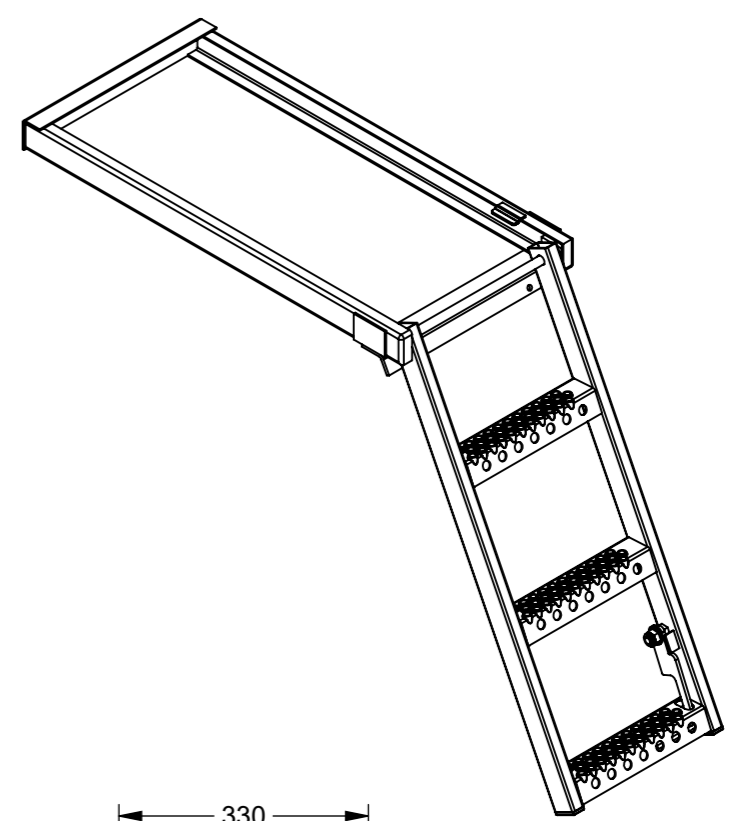
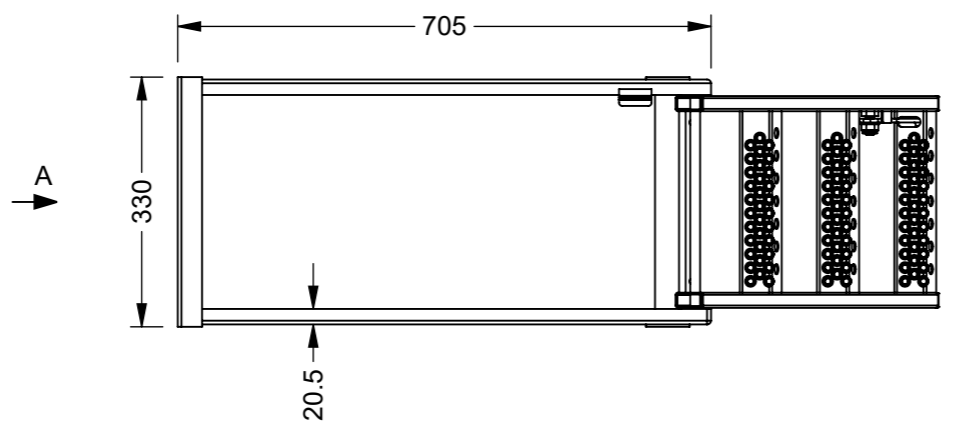
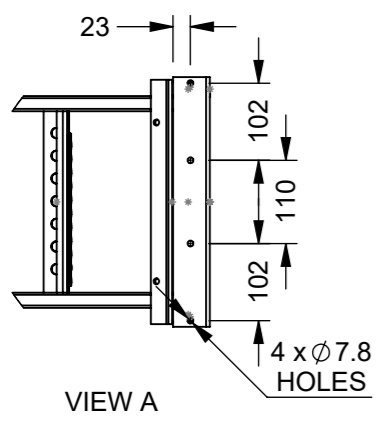

ZONE	REV.	DESCRIPTION	DATE	APPROVED
	1	VALIDATION COMPLETE	24/01/2024	A.P

REVISIONS

UNLESS OTHERWISE STATED, ALL DIMENSIONS IN mm

TOLERANCES		SURFACE FINISH 1.6µm Ra	
0.5 - 6	= ±0.1mm	FILLET RADII	0.5 TO 1.0
6 - 30	= ±0.2 mm	SQUARENESS	0.05 IN 25
30 - 120	= ±0.3 mm	PARALLELISM	0.05 IN 25
120 - 400	= ±0.5 mm	RUNOUT	0.1
400 - 1000	= ±0.8 mm	ANGLES	±0.5°
1000 - 2000	= ±1.2 mm		
2000 - 4000	= ±2.0 mm		

MATERIAL: M/STEEL
 MASS: 8.13
 FINISH: POWDERCOAT YELLOW - KP123CWW

DRAWN BY: UF
 CHECKED BY: A.P
 DESCRIPTION: 3 RUNG STEP - YELLOW

A3

APPROVED BY: A.P
 ORIGINATION DATE: 24/01/2024
 NUMBER: 5326-303Y
 REVISION: 1
 SHEET: 1 of 1

PROPRIETARY RIGHTS ARE INCLUDED IN THE INFORMATION DISCLOSED HEREIN. NEITHER THIS DOCUMENT NOR ANY INFORMATION DISCLOSED SHALL BE REPRODUCED, USED, TRANSFERRED TO OTHER DOCUMENTS, OR DISCLOSED TO OTHERS FOR ANY PURPOSE INCLUDING MANUFACTURING UNLESS SPECIFICALLY AUTHORISED IN WRITING
 REMOVE ALL SHARP EDGES AND BURRS
 PART FINISHING AND MARKING TO CESF001



SCALE : PROPORTIONAL - DO NOT SCALE
 REF SCALE 1:10 WHEN PRINTED ON A3



A
B
C
D
E
F

A
B
C
D
E
F

8 7 6 5 4 3 2 1

8 7 6 5 4 3 2 1