

PARTS LIST			
ITEM	QTY	PART NUMBER	DESCRIPTION
1	1	9820-1182-1	HINGE BASE PLATE
2	1	9820-1182-2	HINGE PIN - 98 O/A
3	1	GREASE NIPPLE	GREASE NIPPLE
4	1	9820-1182-3	HINGE MAIN PLATE

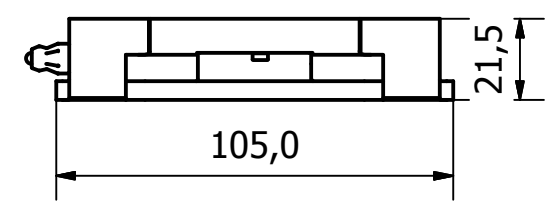
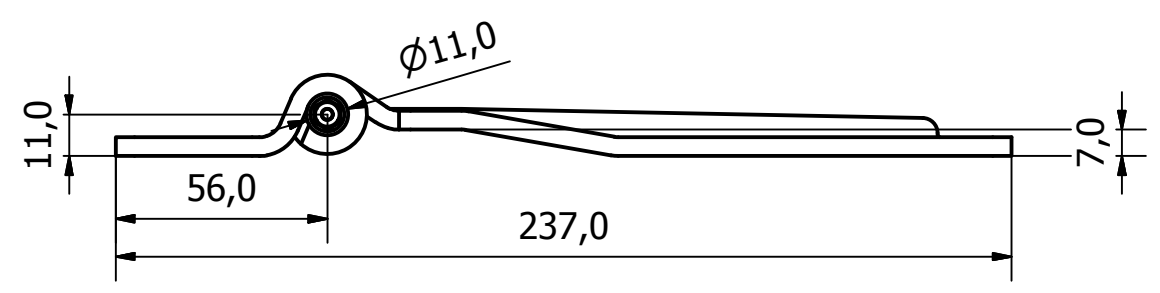
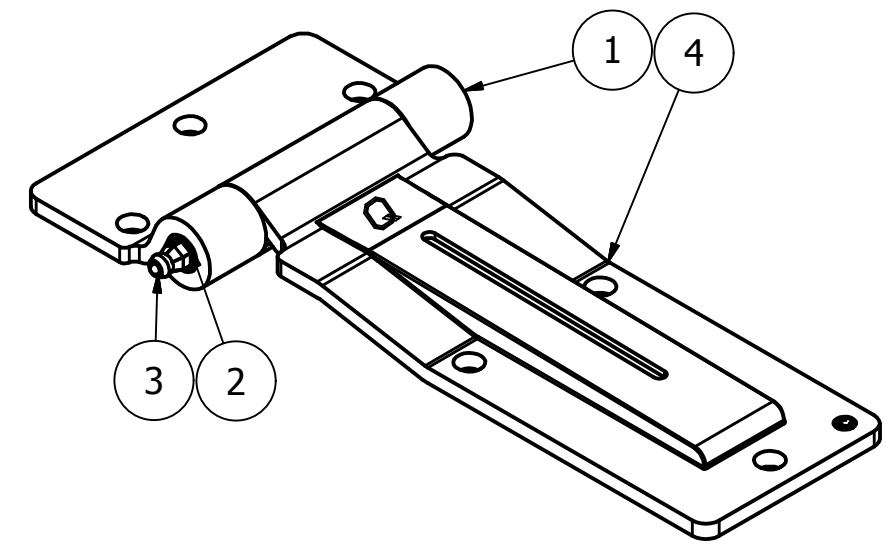

NOTE:  
HINGE DESIGNED FOR 180° APPLICATIONS  
BUT WILL ROTATE THROUGH TO 270°

GENERAL TOLERANCES ON LENGTHS
0.5 - 6 ± 0.1mm
6 - 30 ± 0.2mm
30 - 120 ± 0.3mm
120 - 400 ± 0.5mm
400 - 1000 ± 0.8mm
1000 - 1200 ± 1.2mm
2000 - 4000 ± 2.0mm

ALBERT JAGGER LTD  
GREEN LANE  
WALSALL PHONE: 01922 471000  
WEST MIDLANDS FAX: 01922 648021  
WS2 8HG

THIS DRAWING & THE DESIGN SHOWN  
ARE THE PROPERTY OF ALBERT JAGGER LTD  
AND MUST NOT BE USED OR COPIED BY A  
THIRD PARTY WITHOUT PERMISSION

DRAWN BY  
U.F

CHECKED BY  
A.P

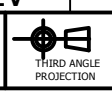

SCALE  
1 : 2

MATERIAL  
-

MASS  
0.929 kg

FINISH  
Z/C  
PASSIVATE

Date  
22/09/2016

ALL DIMS IN MM  
UNLESS STATED  
DO NOT SCALE

A3



PRESSED STEEL HINGE - CRANKED BLADE C/W GREASE NIPPLE RH

9820-1183

Edition  
1

Sheet  
1 / 1